

66" stroke - Ø3 - 16" capacity

Rev 1.0

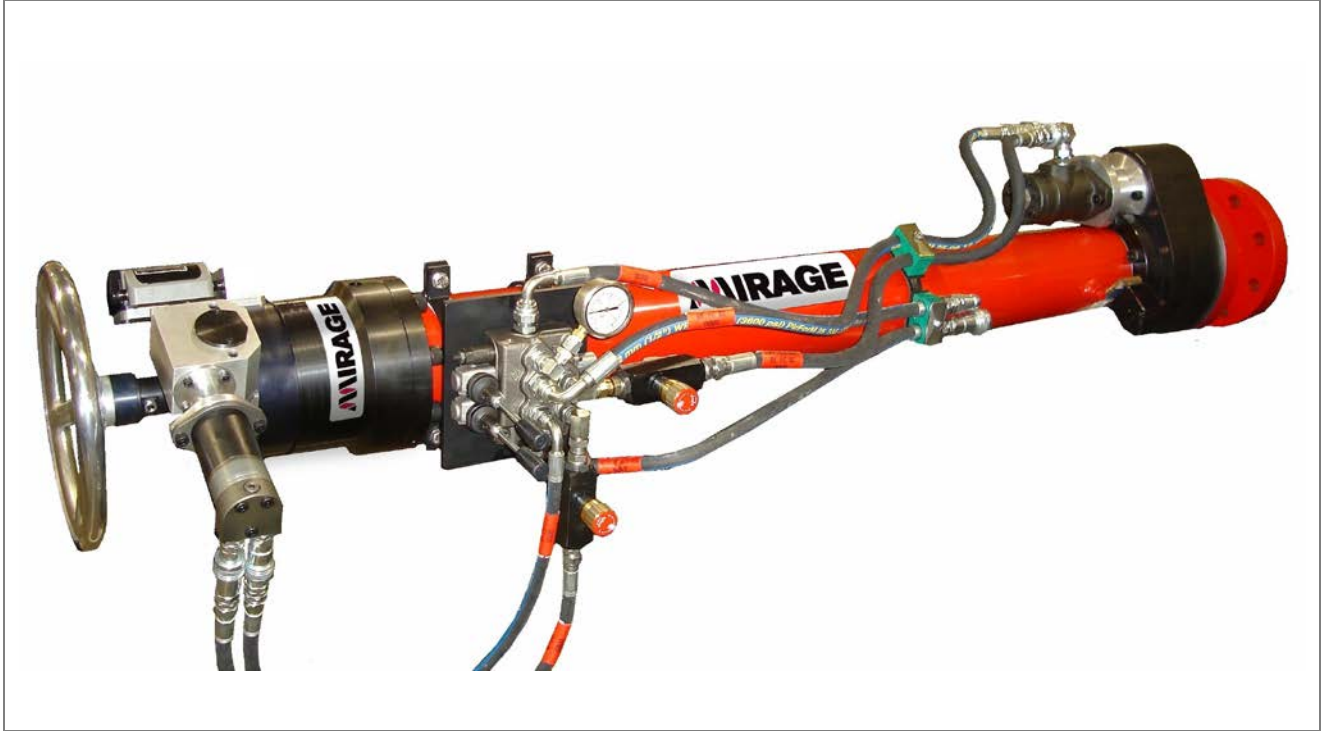

- Helical geared drive
- Drive as close to cutter as possible to optimise cutting performance
- Internally pressure balanced system
- Auto variable feed gearbox and motor - PATENT 0703716.1
- Geared mechanical depth display - International wo2008/104753
- Constant seal & pressure monitoring

A hot tapping machine with a working pressure capacity of 5000 p.s.i maximum and can hot tap from Ø3 - 16" specifically designed for all pipeline intervention and wellhead maintenance.

The machine is supplied complete with feed and drive motor, lifting brackets, (3 - 4"), (6 - 12"), (12 - 16") cutter holders, connection hoses & pressure gauge, toolkit, air filter lubricator (when required), all required mounting studs & nuts and connection spool, storage / shipping box, CE certificate, packing list and manual – pressure certification 1480 psi (100 bar).

Technical Details

Minimum Tapping Hole Diameter	76mm	3"
Maximum Tapping Hole Diameter	405mm	16"
Maximum Certified Operating Pressure	5000 p.s.i	345 bar
Maximum Operating Temperature	110°C (option for 120°C)	230°F (option for 248°F)
Spindle Bar Travel	1675mm	66"
Spindle Bar Minimum Clearance	75mm	3"
R.P.M	Min: 5	Max: 40
Drive - Pneumatic	4.0 Hp	3.0 Kw
Drive - Hydraulic	5.0 Hp	3.7 Kw
Feed - Pneumatic	1.5 Hp	1.11 Kw
Feed - Hydraulic	2.2 Hp	1.64 Kw
Hydraulic Supply Required @ 1050 p.s.i	50 L/min	13 Gal/min
Air Consumption / Supply Required	98 s.c.f.m	2.69 m ³ /m

Feed Rates

Feed Rate – Manual / Revolution	10mm	0.393"
Feed Rate – Auto Feed	0 - 8mm/min	0 - 0.315"/min

Weights and Dimensions

Machine Weight	449 Kgs	988 Lbs
Shipping Weight	580 Kgs	1276 Lbs

Shipping Dimensions

Length		Width		Height	
mm	inches	mm	inches	mm	inches
3080	121"	660	26"	760	31"

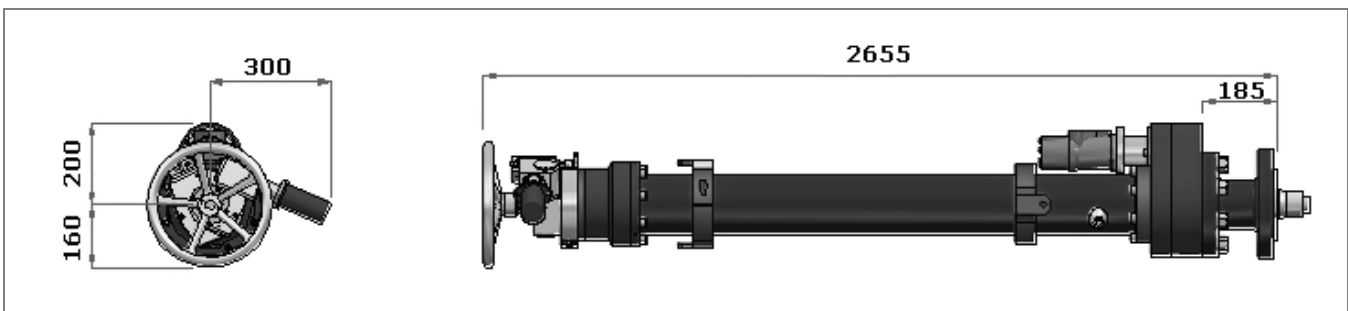

Rev. B/150120

Optional Accessories



HTC3 - HTC36
Standard hot tap cutters
from 3 - 36"



PP1 - 11 Kw 3 Phase Power Pack
56 L.P.M up to 100 bar remote
Pendant

PP4 - 35 Kw Power Pack
Diesel engine silent type, complete with
12 volt control variable delivery axial
piston pump with constant pressure
control, variable output flow, 0 to 80
L.P.M up to 160 bar



SHTPD3 - SHTPD36
Standard hot tap pilot
drills with wire retainers



CHT - 5000PT
Third party pressure test with
calibrated test equipment



LSC4 - LSC36
Line stop cutters 4 - 36"



LSPD4 - LSPD36
Standard line stop pilot drills with wire
retainers



150-3FA - 600-24FA
Standard flange adapters
(3 - 24") #150, #300, #600



Special Flange Adapters
(3 - 24") #900, #2500, PN16, API and
line stop



HTC3EX - HTC36EX
Extended hot tap cutters
from 3 - 36"



SHTPD3EX - SHTPD36EX
Extended hot tap pilot drills 3 - 36"



LSFH4 - LSFH36
Line stop folding heads 4 - 24"



Line stop actuator machines
Manual and hydraulic