

120" stroke - Ø12 - 36" capacity



- Helical geared drive
- Drive as close to cutter as possible
- Internally pressure balanced system
- Auto variable feed gearbox and motor
- Geared mechanical depth display
- Constant seal & pressure monitoring
- PATENT (0703716.1)
- (International wo2008/104753)

A hot tapping machine with a working pressure capacity of 5000 p.s.i maximum and can hot tap from Ø12 - 36" specifically designed for all pipeline intervention and wellhead maintenance.

The machine is supplied complete with feed and drive motor, lifting brackets, (12 - 24"), (24 - 36") cutter holders, connection hoses & pressure gauge, toolkit, air filter lubricator (when required), all required mounting studs & nuts and connection spool, storage / shipping box, CE certificate, packing list and manual – pressure certification 2220 psi (153 bar).

External certification for 5000 psi (345 bar) optional.

Technical Details

Minimum Tapping Hole Diameter	305mm	12"
Maximum Tapping Hole Diameter	915mm	36"
Maximum Working Pressure	345 bar	5000 p.s.i
Standard Certified Operating Pressure	102 bar	1480 p.s.i
Maximum Operating Temperature	110°C (option for 120°C)	230°F (option for 248°F)
Spindle Bar Travel	3000mm	120"
Spindle Bar Minimum Clearance	152mm	6"
R.P.M	Min: 5	Max: 40
Drive - Hydraulic	35.0 Hp	26.0 Kw
Hydraulic Supply Required @ 1050 p.s.i	60 L/min	16 Gal/min

Feed Rates

Feed Rate – Manual / Revolution	10mm	0.393"
Feed Rate – Auto Feed	0 - 8mm/min	0 - 0.315"/min

Weights and Dimensions

Machine Weight	2120 Kgs	4664 Lbs
Shipping Weight	2422 Kgs	5328 Lbs

Shipping Dimensions

Length		Width		Height	
mm	inches	mm	inches	mm	inches
4790	188"	1250	49"	930	37"

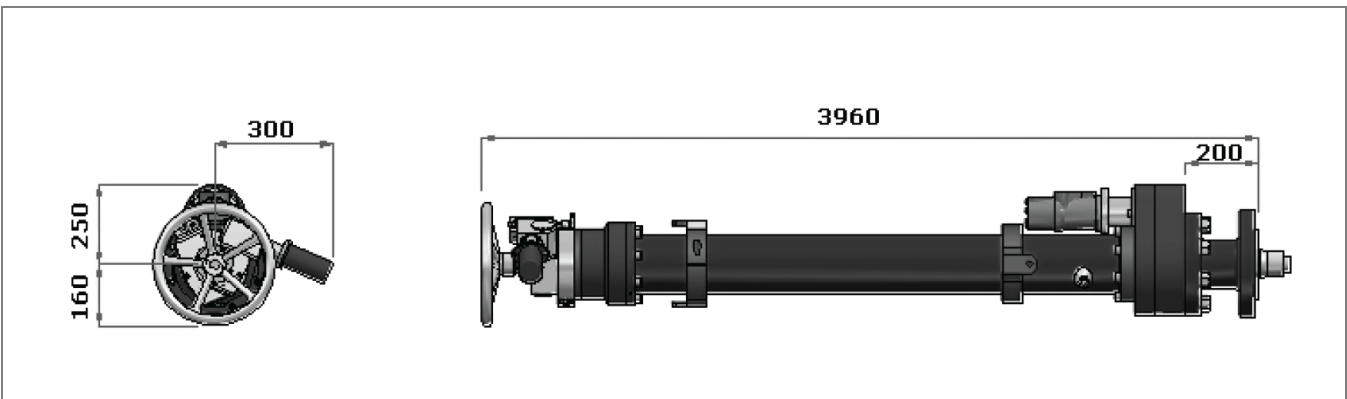

Optional Accessories



HTC3 - HTC36
Standard hot tap cutters
from 3 - 36"



PP1 - 11 Kw 3 Phase Power Pack
56 L.P.M up to 100 bar remote
Pendant

PP4 - 35 Kw Power Pack
Diesel engine silent type, complete with
12 volt control variable delivery axial
piston pump with constant pressure
control, variable output flow, 0 to 80
L.P.M up to 160 bar



SHTPD3 - SHTPD36
Standard hot tap pilot
drills with wire retainers

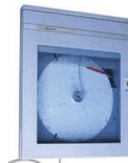

CHT - 5000PT
Third party pressure test with
calibrated test equipment



LSC4 - LSC36
Line stop cutters 4 - 36"



LSPD4 - LSPD36
Standard line stop pilot drills with wire
retainers



150-3FA - 600-24FA
Standard flange adapters
(3 - 24") #150, #300, #600



Special Flange Adapters
(3 - 24") #900, #2500, PN16, API and
line stop



HTC3EX - HTC36EX
Extended hot tap cutters
from 3 - 36"



SHTPD3EX - SHTPD36EX
Extended hot tap pilot drills 3 - 36"



LSFH4 - LSFH36
Line stop folding heads 4 - 24"



Line stop actuator machines
Manual and hydraulic