

40" stroke - Ø3 - 12" capacity

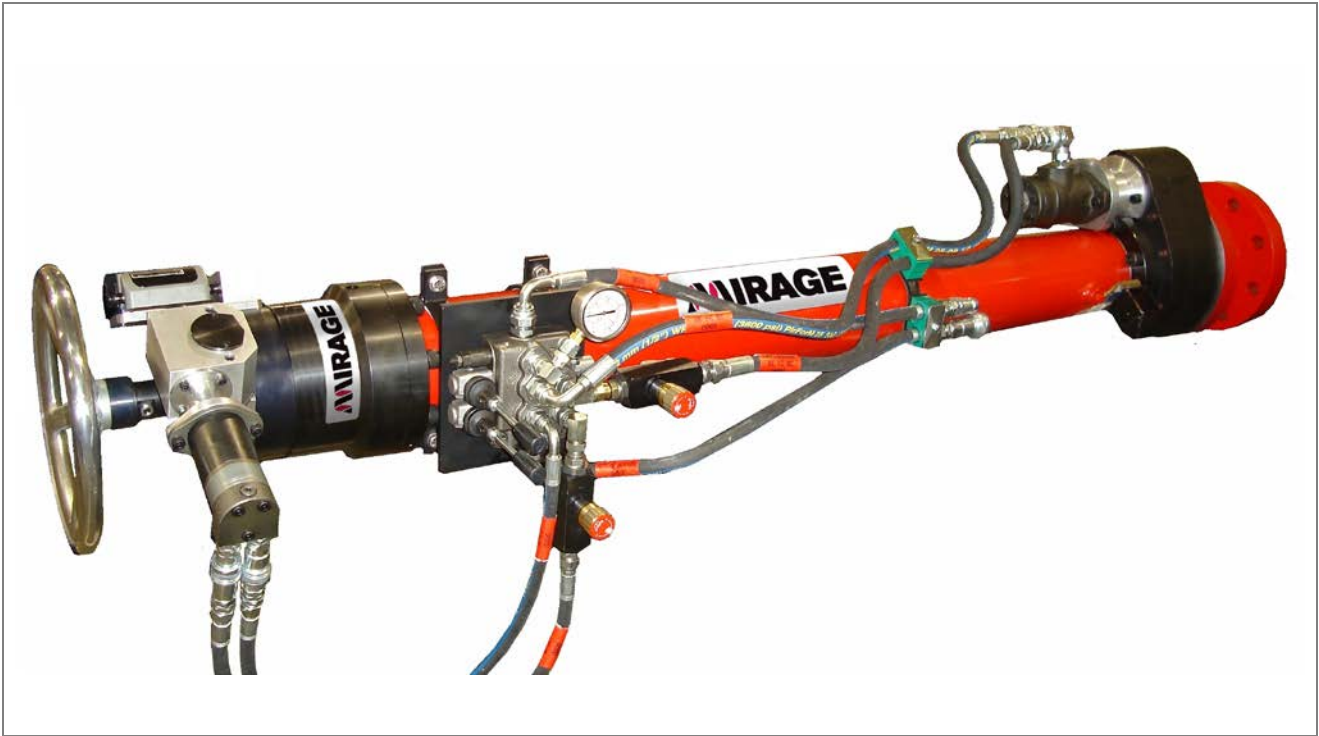

- Helical geared drive
- Drive as close to cutter as possible to optimise cutting performance
- Internally pressure balanced system
- Auto variable feed gearbox and motor - PATENT 0703716.1
- Geared mechanical depth display - International wo2008/104753
- Constant seal & pressure monitoring

A hot tapping machine with a working pressure capacity of 5000 p.s.i maximum and can hot tap from Ø3 - 12" specifically designed for all pipeline intervention and wellhead maintenance.

The machine is supplied complete with feed and drive motor, lifting brackets, (3 - 4"), (6 - 12") cutter holders, connection hoses & pressure gauge, toolkit, air filter lubricator (when required) , all required mounting studs & nuts and connection spool, storage / shipping box, CE certificate, packing list and manual – pressure certification 1480 psi (100 bar).

## Technical Details

Minimum Tapping Hole Diameter	76mm	3"
Maximum Tapping Hole Diameter	305mm	12"
Maximum Certified Operating Pressure	5000 p.s.i	345 bar
Maximum Operating Temperature	200°C	392°F
Spindle Bar Travel	1000mm	40"
Spindle Bar Minimum Clearance	75mm	3"
R.P.M	Min: 5	Max: 40
Drive - Pneumatic	4.0 Hp	3.0 Kw
Drive - Hydraulic	5.0 Hp	3.7 Kw
Feed - Pneumatic	1.5 Hp	1.11 Kw
Feed - Hydraulic	2.2 Hp	1.64 Kw
Hydraulic Supply Required @ 1050 p.s.i	50 L/min	13 Gal/min
Air Consumption / Supply Required	98 s.c.f.m	2.69 m <sup>3</sup> m

## Feed Rates

Feed Rate – Manual / Revolution	10mm	0.393"
Feed Rate – Auto Feed	0 - 8mm/min	0 - 0.315"/min

## Weights and Dimensions

Machine Weight	345 Kgs	759 Lbs
Shipping Weight	517 Kgs	1137 Lbs

## Shipping Dimensions

Length		Width		Height	
mm	inches	mm	inches	mm	inches
2280	90	930	36"	700	28"

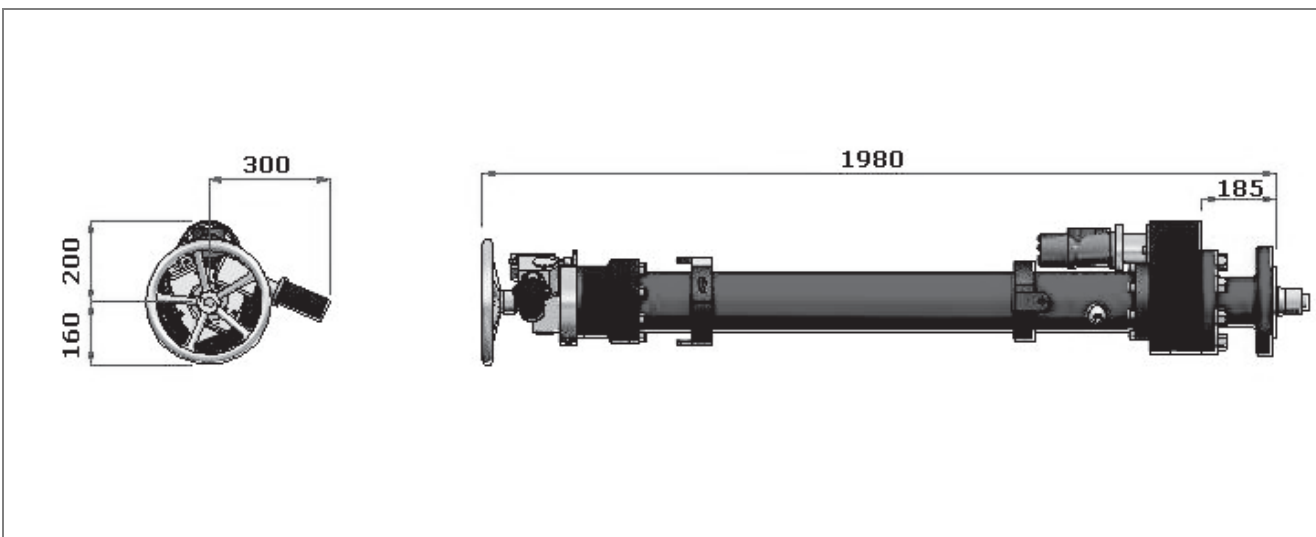

## Optional Accessories



**HTC3 - HTC36**  
Standard hot tap cutters  
from 3 - 36"



**PP1 - 11 Kw 3 Phase Power Pack**  
56 L.P.M up to 100 bar remote  
Pendant

**PP4 - 35 Kw Power Pack**  
Diesel engine silent type, complete  
with 12 volt control variable delivery  
axial piston pump with constant  
pressure  
control, variable output flow, 0 to 80  
L.P.M up to 160 bar



**SHTPD3 - SHTPD36**  
Standard hot tap pilot  
drills with wire retainers



**CHT - 5000PT**  
Third party pressure test with  
calibrated test equipment



**LSC4 - LSC36**  
Line stop cutters 4 - 36"



**LSPD4 - LSPD36**  
Standard line stop pilot drills with  
wire retainers



**150-3FA - 600-24FA**  
Standard flange adapters  
(3 - 24") #150, #300, #600



**Special Flange Adapters**  
(3 - 24") #900, #2500, PN16, API and  
line stop



**HTC3EX - HTC36EX**  
Extended hot tap cutters  
from 3 - 36"



**SHTPD3EX - SHTPD36EX**  
Extended hot tap pilot drills 3 - 36"



**LSFH4 - LSFH36**  
Line stop folding heads 4 - 24"



**Line stop actuator machines**  
Manual and hydraulic