

120" stroke -  $\varnothing$ 12 - 36" capacity

Rev 1.0



- Helical geared drive
- Drive as close to cutter as possible to optimise cutting performance
- Internally pressure balanced system
- Auto variable feed gearbox and motor - PATENT 0703716.1
- Geared mechanical depth display - International wo2008/104753
- Constant seal & pressure monitoring

A hot tapping machine with a working pressure capacity of 5000 p.s.i maximum and can hot tap from  $\varnothing$ 12 - 36" specifically designed for all pipeline intervention and wellhead maintenance.

The machine is supplied complete with feed and drive motor, lifting brackets, (12 - 24"), (24 - 36") cutter holders, connection hoses & pressure gauge, toolkit, air filter lubricator (when required), all required mounting studs & nuts and connection spool, storage / shipping box, CE certificate, packing list and manual – pressure certification 2220 psi (153 bar).

External certification for 5000 psi (345 bar) optional.

## Technical Details

|                                        |                          |                          |
|----------------------------------------|--------------------------|--------------------------|
| Minimum Tapping Hole Diameter          | 305mm                    | 12"                      |
| Maximum Tapping Hole Diameter          | 915mm                    | 36"                      |
| Maximum Certified Operating Pressure   | 5000 p.s.i               |                          |
| Maximum Operating Temperature          | 110°C (option for 120°C) | 230°F (option for 248°F) |
| Spindle Bar Travel                     | 3000mm                   | 120"                     |
| Spindle Bar Minimum Clearance          | 152mm                    | 6"                       |
| R.P.M                                  | Min: 5                   | Max: 40                  |
| Drive - Hydraulic                      | 35.0 Hp                  | 26.0 Kw                  |
| Hydraulic Supply Required @ 1050 p.s.i | 60 L/min                 | 16 Gal/min               |

## Feed Rates

|                                 |             |                |
|---------------------------------|-------------|----------------|
| Feed Rate – Manual / Revolution | 10mm        | 0.393"         |
| Feed Rate – Auto Feed           | 0 - 8mm/min | 0 - 0.315"/min |

## Weights and Dimensions

|                 |          |          |
|-----------------|----------|----------|
| Machine Weight  | 2120 Kgs | 4664 Lbs |
| Shipping Weight | 2422 Kgs | 5328 Lbs |

## Shipping Dimensions

| Length |        | Width |        | Height |        |
|--------|--------|-------|--------|--------|--------|
| mm     | inches | mm    | inches | mm     | inches |
| 4790   | 188"   | 1250  | 49"    | 930    | 37"    |

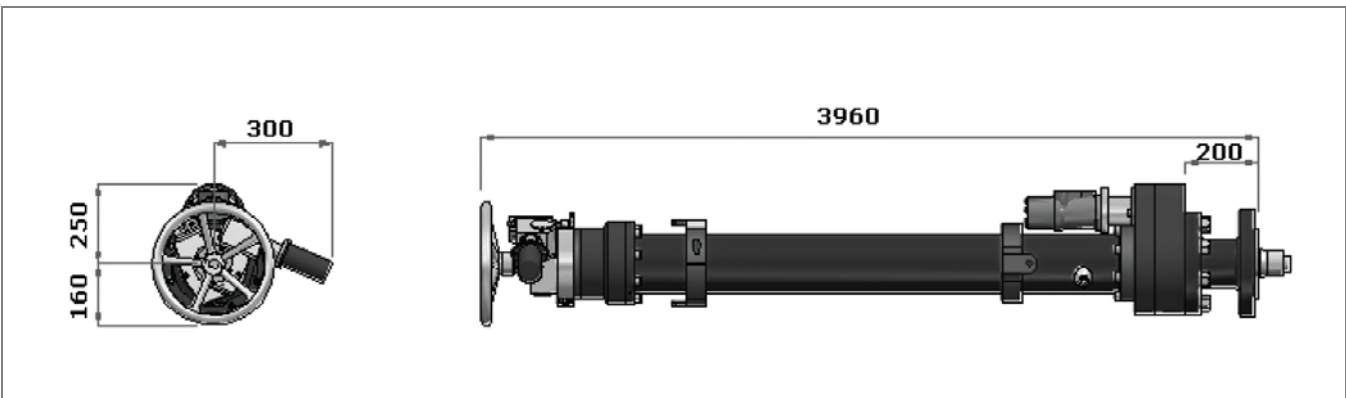

Rev. B/150120

## Optional Accessories



**HTC3 - HTC36**  
Standard hot tap cutters  
from 3 - 36"



**PP1 - 11 Kw 3 Phase Power Pack**  
56 L.P.M up to 100 bar remote  
Pendant

**PP4 - 35 Kw Power Pack**  
Diesel engine silent type, complete with  
12 volt control variable delivery axial  
piston pump with constant pressure  
control, variable output flow, 0 to 80  
L.P.M up to 160 bar



**SHTPD3 - SHTPD36**  
Standard hot tap pilot  
drills with wire retainers



**CHT - 5000PT**  
Third party pressure test with  
calibrated test equipment



**LSC4 - LSC36**  
Line stop cutters 4 - 36"



**LSPD4 - LSPD36**  
Standard line stop pilot drills with wire  
retainers



**150-3FA - 600-24FA**  
Standard flange adapters  
(3 - 24") #150, #300, #600



**Special Flange Adapters**  
(3 - 24") #900, #2500, PN16, API and  
line stop



**HTC3EX - HTC36EX**  
Extended hot tap cutters  
from 3 - 36"



**SHTPD3EX - SHTPD36EX**  
Extended hot tap pilot drills 3 - 36"



**LSFH4 - LSFH36**  
Line stop folding heads 4 - 24"



**Line stop actuator machines**  
Manual and hydraulic